



CASPR™ TECHNOLOGIES



HOME PRO OWNER'S MANUAL

The information in this manual is applicable to these HVAC

units: CASPR Home PRO 9 | CASPR Home PRO 14

CAUTION: Read manual carefully for proper procedures and operation.

Congratulations

on your purchase of a CASPR Technologies enhanced air and surface disinfection system. This unit is designed to be mounted into central HVAC duct systems. Please read and follow all safety warnings and service procedures outlined in this manual. Use only genuine CASPR Technologies replacement parts available from your CASPR Technologies Distributor.

If you have any questions concerning this or any CASPR Technologies product, contact your CASPR Technologies Distributor.

Principles of Operation

CASPR Home PRO uses Natural Catalytic Conversion (NC²I) to generate safe, low levels of hydrogen peroxide. NC²I technology replicates natural purifying processes by using a high intensity light to activate a proprietary metal catalytic coating, converting water vapor into hydrogen peroxide. Hydrogen peroxide acts as an oxidizer inactivating surface and air pathogens. It can compromise cellular integrity by disrupting cell walls, or internal molecular structures, rendering contaminants harmless.

To learn more about this and other CASPR Technologies products, please visit our website at www.casprtech.com.

Table of Contents

Warnings.....	3
Specifications.....	4
Product Contents.....	4
Installation Hardware.....	5
Replacement Parts.....	5
Recommended Installation Tools.....	5
Electrical Requirement.....	6
Hard-Wiring Requirement.....	6
Installation Requirement.....	6
Installation Instructions.....	7
Alternative Cutting Method.....	8
Installation (continued).....	9
Indicator Lights.....	10
Maintenance.....	11
Disposal Of The NC ² I Cell.....	11
Changing The NC ² I Cell.....	11
Changing The NC ² I Cell (continued).....	12
Troubleshooting Q&A.....	13
Warranty Information.....	14

IMPORTANT SAFETY INSTRUCTIONS





When using an electrical appliance, basic precautions should always be taken.

READ ALL INSTRUCTIONS BEFORE USING THIS PRODUCT

WARNING!

To reduce the risk of fire, electrical shock, or injury:

- Use only as described in this manual.
- Do not attempt to repair or adjust any of the electrical or mechanical functions. Contact Customer Service for service information.
- Do not use outdoors or on wet surfaces.
- Do not allow to be used as a toy. Do not allow children around the unit.
- Do not handle with wet hands.
- **Do not touch NC2I bulb with bare hands.**

 WARNING	
 	<p>WARNING! - UV light in operation. Disconnect unit from power supply before servicing. Failure to follow warnings may result in severe eye damage.</p>
	<p>WARNING! - Unit should be mounted at least 24 inches from the heat exchanger or heating element. Placing the photocatalytic cell too close to the heating element can cause the photocatalytic matrix to combust.</p>
	<p>To reduce the risk of electric shock, this equipment may have a grounding type plug that has a third (grounding) pin. This plug will only fit into a grounding type power outlet. If the plug does not fit into the outlet, contact an HVAC professional to install the proper outlet. Do not alter the plug in any way.</p>

Specifications

Unit	Coverage	Size (HxWxD)*	Weight	Watts	Amps DC 24V	Amps AC 120V
CASPR Home PRO 9	10,000 ft ³	9.75" x 9.75" x 11"	3.1 lb	10	0.64	0.30
CASPR Home PRO 14	25,000 ft ³	9.75" x 9.75" x 16.75"	3.3 lb	18	1.0	0.44

Product Contents

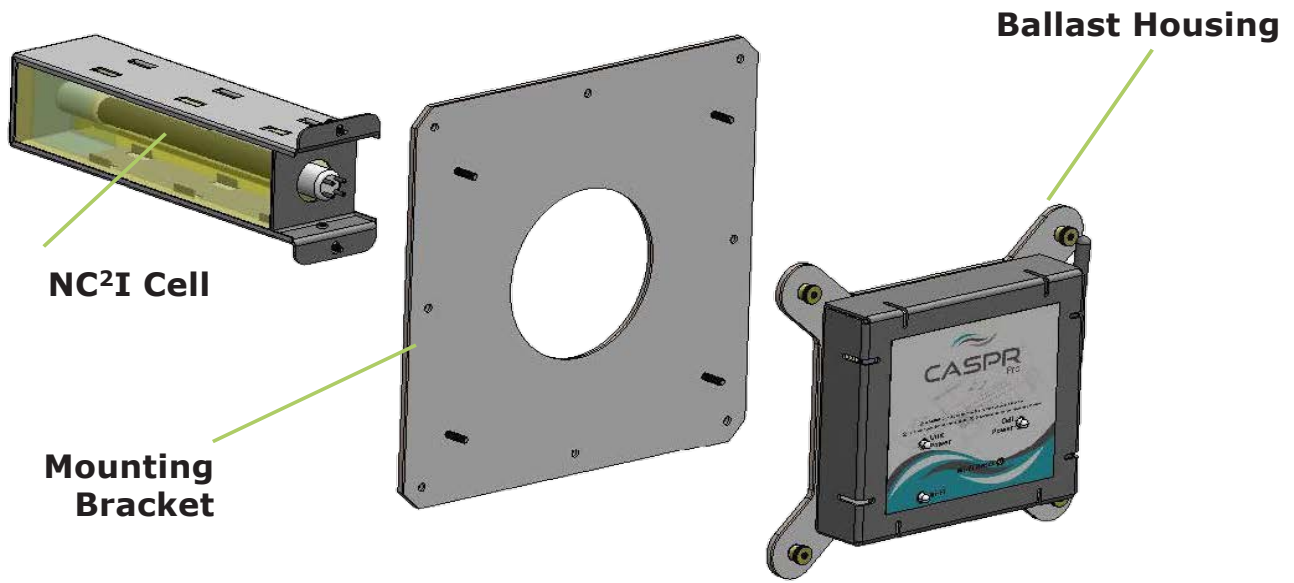

Installation Hardware

- (8) #8 3/4 Hex Self-tapping Screws
- (4) Flange Nuts
- (2 or 4) Cell Mounting Screws (2 screws per NC²I Cell)

Replacement Parts

The NC²I Cell and bulb should be replaced every 18-24 months. Please contact your distributor for new replacements.

CASPR HomePro9 NC²I Cell Part Number: CELL-HV-9-001-AP

CASPR HomePro14 NC²I Cell Part Number: CELL-HV-14-001-AP

Recommended Installation Tools

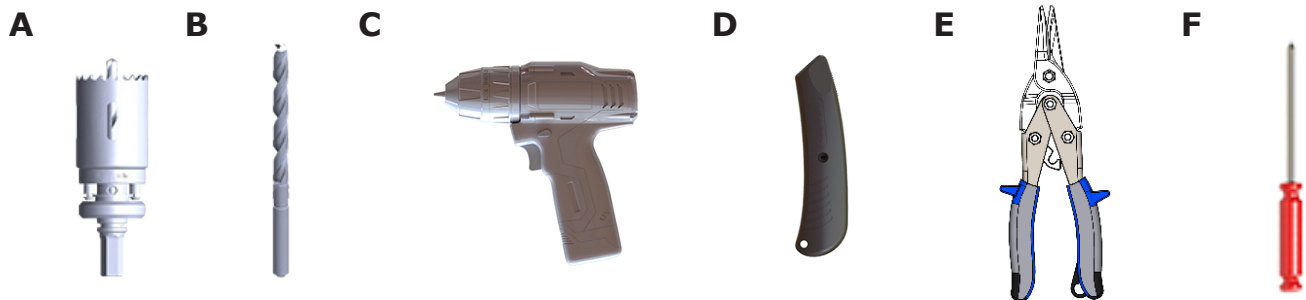

A - 4" Hole Saw Bit

B - 3/8" Drill Bit

C - Drill/Power Driver

D - Utility Knife

E - Tin Snips

F - Phillips Head Screwdriver

Electrical Requirement

All CASPR Home PRO duct mounted units run on DC 24V. Each unit comes with a power adapter that will take AC 100-240V. We recommend locating the unit within 6 ft. of a standard 120V Grounded outlet to plug in directly. Long term use on an extension cord is not recommended due to safety considerations.

If an outlet is not available within 6 feet of the installation location, you may hardwire the unit into the HVAC system using a licensed HVAC professional.

Hard-Wiring Requirement

Permanent wiring of the unit into your HVAC system may be completed using a hardwire assembly (sold separately) and should be done by a licensed HVAC Installer or Electrical Contractor only.

For 110V or 220V Applications: Black = L1, White = Neutral,
Green = Ground

For International Applications: Brown = L1, Blue = L2,
Green/Yellow = Ground

If DC 24V is available, splice the wire **between** the brick and the cell housing to wire directly to the unit circumventing the power brick.

If the voltage is higher than AC 120-240V, you will need a transformer that converts your supply voltage to DC 24V eliminating the power brick.

When hardwiring any of these units please be mindful of the Maximum Amp draw that your power supply transformer can handle to prevent damage (Equation: Power Supply Transformer Amps / CASPR Volts = Maximum Amp Load).

Installation Requirement

1. Unit should be installed downstream of the air handler in the HVAC system.*
- **Additional HVAC units may be installed in the Return Plenum for added protection and to keep the internal parts clean.
2. The duct work around the installation area should be cleaned and dry to insure proper adhesion of the gasket materials and any tape used.
3. One-two 4" circular openings will need to be cut into the existing duct work to install the unit properly.

*HVAC Supply Plenum

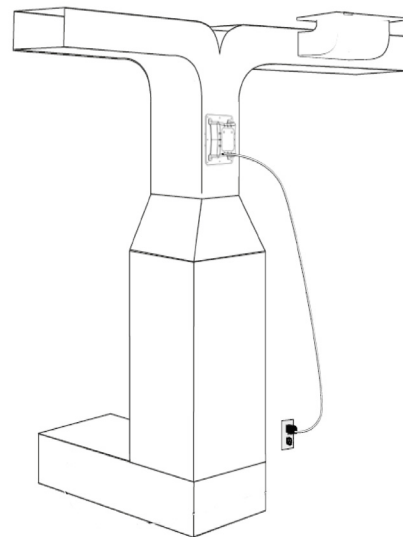

** See Note Above

Installation Instructions

Diagrams are representative of the CASPR Home PRO 9 and Home PRO 14.
The steps are the same for the

1. Find a suitable location to mount your Unit.

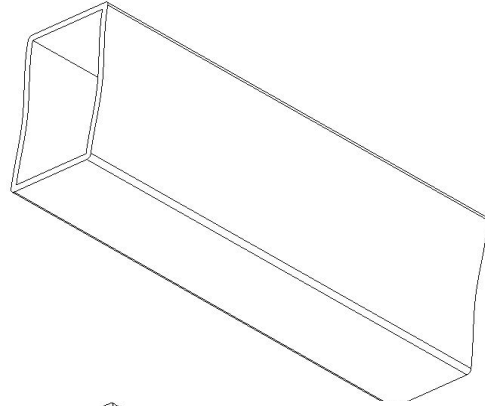

2. If necessary, cut away insulation for your plate to adhere to the duct.

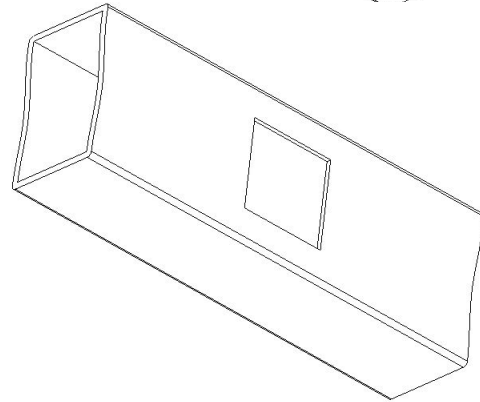

3. Using the Adhesive Mounting Bracket, trace the hole location onto the duct.

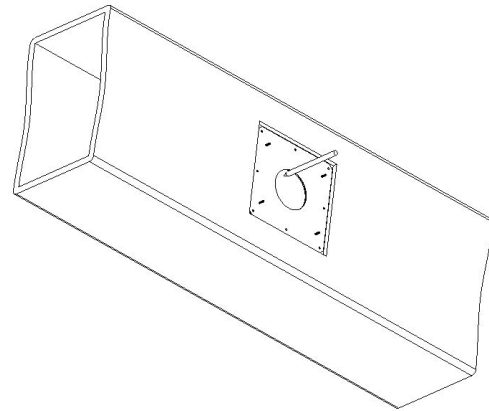

4. Use the Hole Saw and Drill to cut out the marked hole.

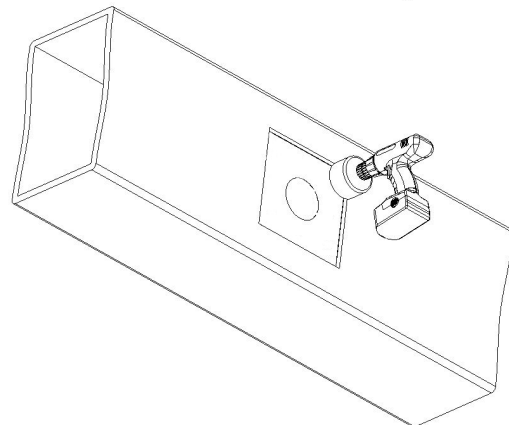

Alternative Cutting Method

1. Using the Adhesive Mounting Bracket, trace the hole location onto the duct.

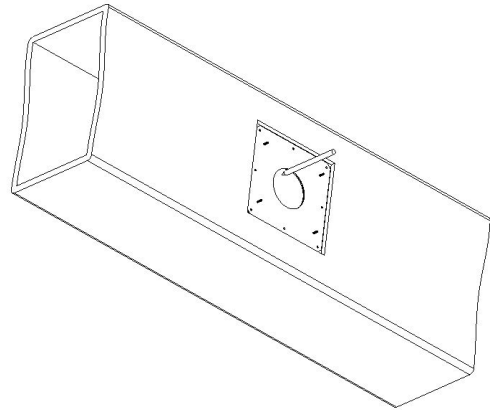

2. Drill holes around the outside edges of the previously marked hole but inside the outer holes of the Adhesive Mounting Bracket.

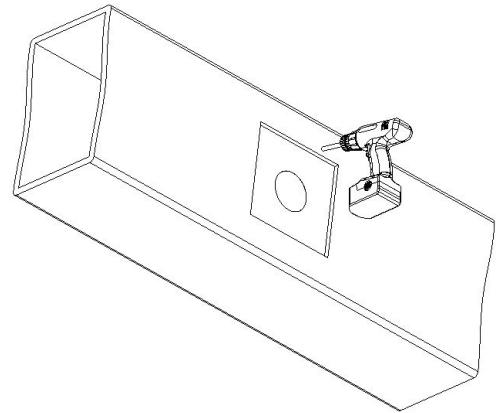

3. Use the Tin Snips to cut out the space around the marked hole.

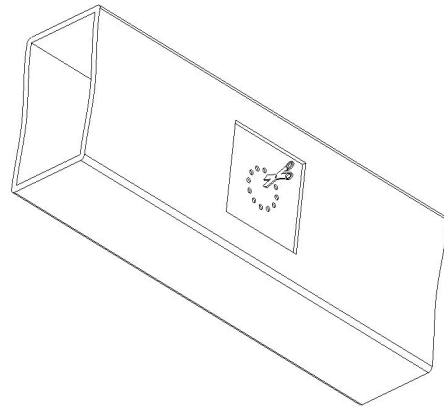

4. Remove the plastic backing on your Adhesive Mounting Bracket.

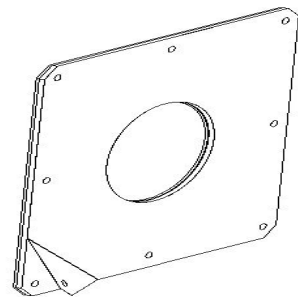

Installation (continued)

5. Press the Adhesive Mounting Bracket onto the duct. Secure with the (8 Self-Tapping Screws).

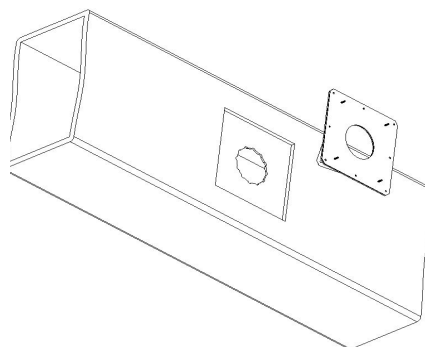

6. Remove the packing foam from the NC²I Cell



DO NOT TOUCH BULB WITH BARE HANDS

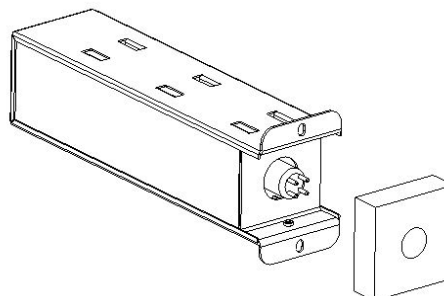

7. Connect the Cell to the Ballast Housing using the (2) Cell Mounting Screws provided. Repeat this step if you have a double cell unit.

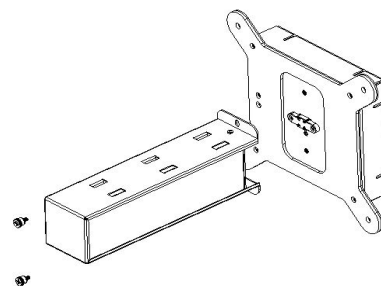

8. Place the unit and cell through the opening and align the four studs with the four holes in the Ballast Housing. Secure the unit with the (4) Flange Nuts until it is flush with the duct. **MAKE SURE THE AIRFLOW MOVES THROUGH THE NC²I CELL** (Refer to orientation and airflow above).

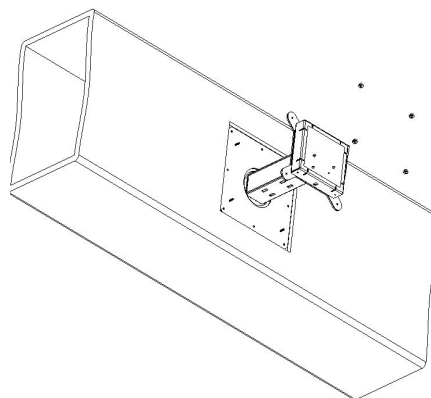

9. Plug the Power Cable into the receptacle or have a Licensed Electrician or HVAC Installer hard wire the unit directly into the HVAC system.

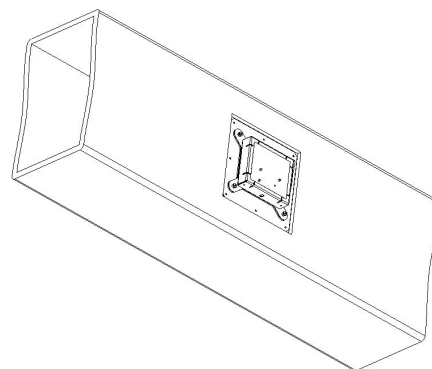

Indicator Lights

- Unit Power - Red light is ON.
- Cell Power - Red light is ON.
 - o Red light ON - Bulbs are on.
 - o Red light OFF - bulb has burned out and needs to be replaced.

**NOTE: THIS MODEL IS NOT WIFI ENABLED;
The Wi-Fi indicator light will not function**



Maintenance

Your CASPR Home PRO unit requires no periodic maintenance beyond normal replacement of the NC²I cells and bulbs every 18-24 months. We recommend the replacement of the NC²I cells and bulbs, even if the bulb appears to be operating normally.

The bulb operation indicator on the face of the unit will glow when the bulb is in use. If the indicator does not glow and the unit has power, the NC²I cell and bulb should be replaced.

Disposal of the NC²I Cell

Please do not throw the used NC²I Cells or bulbs in the garbage.

The high intensity bulb used in the CASPR Home PRO unit contains a very small amount of mercury. Contact your local Waste Management Center for a proper disposal procedure.

Changing the NC²I Cell

1. Remove the Power Cable from the receptacle or ensure the unit isn't powered.
2. Remove the (4) Flange Nuts from the Unit Cover and Remove the Unit Cover and NC²I Cell.
3. Remove the (2) Screws holding the NC²I Cell in place and remove the NC²I Cell from the Unit Cover.

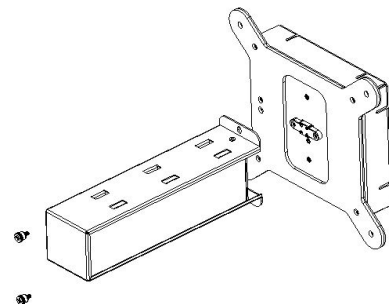
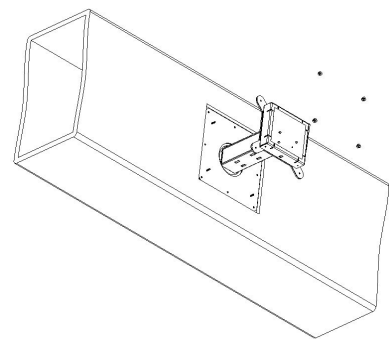
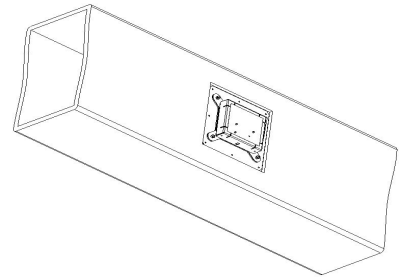

Changing the NC²I Cell Continued

1. Remove the packing foam from the new NC²I Cell

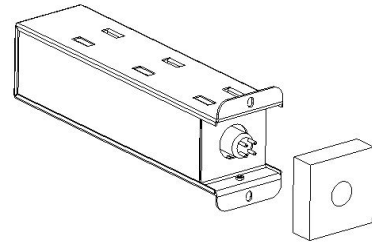

2. Exchange the Old NC²I Cell with the new NC²I Cell and replace the (2) Screws that hold it in place.

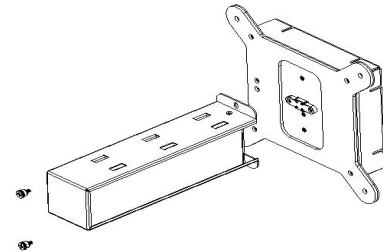

3. Replace the Cover and NC²I Cell in the duct and secure with the (4) Flange Nuts. **MAKE SURE THE AIRFLOW MOVES THROUGH THE NC²I CELL** (Refer to orientation and airflow above).

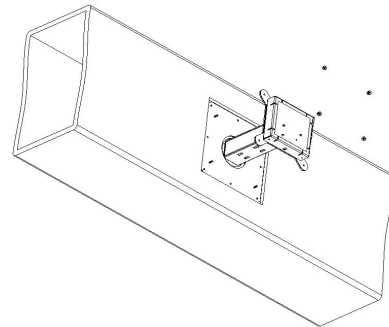

4. Place the Power Cable back into the receptacle or repower your unit.

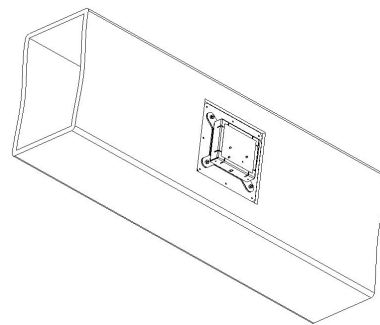

Troubleshooting Q&A

1. How big is the cut hole?

A. You must cut a 4" diameter hole.

2. What power does it run on? (Voltage)

A. You may use an AC 120VAC (With transformer) or a DC/AC 24V Direct. Remember that the wire must be cut and spliced in order to properly connect to the device (Please see hard wiring requirements).

3. How do I know that it is working?

A. The Indicator Lights, on the cell housing, will be on (red) indicating that the ballast and NC²I cell have power and are on. Please see Indicator Lights section above for more information.

4. What should I do if there is no power to the unit?

A. Check each connection point to ensure it is properly connected, if this does not work, please contact your distributor.

5. How often does the bulb need to be changed?

A. The NC²I cells and bulbs need to be replaced once every 18-24 months.

6. How does it mount? (Adhesive or Screws)

A. It mounts using the self-tapping screws NOT the adhesive.

Warranty Information

NDS Sales LLC d/b/a CASPR Technologies (as “Seller”) offers the following Express Limited Warranty to a buying customer (a “Buyer”) of a CASPR product (the “Product”):

Seller warrants to Buyer that (a) the Product will be free from defects caused by faulty workmanship or materials for three years from date of purchase when operated under normal conditions and in accordance with Seller’s recommended use (the “Product Warranty Period),” and that (b) the Components (comprised of a bulb and a cell) will be free from defects caused by faulty workmanship or materials for one year from date of purchase when operated under normal conditions and in accordance with Seller’s recommended use (the “Components Warranty Period).”

SELLER EXPRESSLY DISCLAIMS ALL OTHER WARRANTIES, WHETHER EXPRESS OR IMPLIED.

Should Buyer discover a covered defect within the Product Warranty Period or the Components Warranty Period, Seller will repair or replace (at Seller’s cost) the Product and/or the Components. Buyer’s sole and exclusive remedy for Product or Components defects is limited to repair or replacement.

To confirm coverage or to schedule repair or replacement under this Express Limited Warranty, Buyer should contact Seller at www.casprtech.com/warranty and provide the serial number located on the Product and proof of purchase. Absence of a serial number or proof of purchase may void the Express Limited Warranty.

This Express Limited Warranty does not extend to or cover Product damage caused by accident, fire, flooding, exposure to temperature extremes, abuse, misuse, improper or unauthorized installation, modification, misapplication, or repairs performed by persons other than Seller. Repairs performed by persons other than Seller or Seller’s authorized representative will void the Express Limited Warranty.

This Express Limited Warranty does not extend to or cover incidental or consequential damages incurred by Buyer arising from, related to, or in connection with, any Product or Components defects, including but not limited to downtime costs, loss of use, loss of revenue, and/or loss of profits.

SALES THROUGH DISTRIBUTOR OR RESELLER

To the extent the Product is purchased by Buyer from an authorized CASPR distributor or reseller, this Express Limited Warranty passes through to Buyer.

FOR U.S. APPLICATION ONLY

Product warranties are governed by state and federal laws and may vary from state to state. This Express Limited Warranty provides Buyer with specific assurances regarding repair or replacement of the Product. Other warranties are expressly negated.

FOR CANADIAN APPLICATION ONLY

Canadian, provincial, and territorial sales laws may govern implied warranties. This Express Limited Warranty provides Buyer with specific assurances regarding repair or replacement of the Product. Other warranties are expressly negated. Should there be a difference between this Express Limited Warranty and Canadian law regarding implied warranties, Canadian law will control.



CASPRTM
TECHNOLOGIES

WWW.CASPRTECH.COM

620 LOTUS DRIVE N,
MANDEVILLE, LA 70471
(844) 717-8819